

SigenStor-(5S-12S), SigenStor-(5T-30T) Series

User Manual

Version: 06

Release date: 2025-12-16



Copyright Notice

Copyright© 2025 SigenergyTechnology Co., Ltd. All Rights Reserved.

Description in this document may contain predictive statements regarding financial and operating results, product portfolio, new technology, configurations and features of product. Several factors could cause difference between actual results and those expressed or implied in the predictive statements. Therefore, description in this document is provided for reference purpose only and constitutes neither an offer nor an acceptance. Sigenergy Technology Co., Ltd. may change the information at any time without notice.



SIGENERGY and other Sigenergy trademarks are owned by Sigenergy Technology Co., Ltd.

All trademarks and registered trademarks in this document belong to their owners.



Website



LinkedIn



YouTube

www.sigenergy.com

Contents

Revision History	04
Overview	05
Chapter 1 Safety Precautions	6
Chapter 2 Introduction to Energy Storage Systems	08
2.1 Product Model	08
2.2 Appearance Introduction	13
2.2.1 Appearance and Dimensions	13
2.2.2 Port Introduction	15
2.2.3 Label Instructions	18
2.3 Supported grid power supply modes	19
2.4 Typical Networking Introduction	21
Chapter 3 Site Selection Requirements	26
Chapter 4 Equipment Installation and Wiring	29
Chapter 5 System Operation	30
5.1 Operation Modes	30
5.2 Power Station Backup Power Setting	33
5.3 Peak Shaving Control Mode	34
5.4 LED indicator status	37
5.5 mySigen App Query and Settings	39
Chapter 6 System Maintenance	40
6.1 Routine Maintenance	40
6.2 System Power Off/On	41
6.3 Low SOC	43
6.4 Emergency Treatment	44
Chapter 7 Technical Parameters	46
Chapter 8 FAQs	47

Revision History

Version	Date	Description
06	2025.12.16	Update Product Model Update FAQs
05	2025.09.30	Update Site Selection Requirements
04	2025.08.13	Update Introduction to Energy Storage Systems Update Site Selection Requirements
03	2025.02.17	Update Operation Modes Update Power Station Backup Power Setting Update Peak Shaving Control Mode
02	2024.10.17	Update System Power Off/On
01	2024.08.01	First official release

Overview

Overview



This document describes product introduction, networking, system operation and maintenance of SigenStor-(5S-12S) and SigenStor-(5T-30T) Series (hereinafter referred to as SigenStor).

Readers

This document is applicable to product users and professionals.

Sign Definition

The following signs may be used in the document to indicate security precautions or key information. Before installation and operation, familiarize yourself with signs and their definitions.

Icon	Definition
 Danger	Danger. Failure to comply will result in death or serious personal injury.
 Warning	Warning. Failure to comply will result in serious personal injury or property damage.
 Caution	Caution. Failure to comply will result in property damage.
Tips	Important or key information, and supplementary operation tips.

Chapter 1 Safety Precautions

Basic Information

Please familiarize yourself with the contents of this manual before installing, operating, and maintaining the equipment.

The "Caution", "Warning", and "Danger" items described in the manual serve only as supplements to all safety precautions.

Our company shall not be liable for equipment damage or property losses caused by the following reasons:

- Failure to obtain permission from national or regional power authorities.
- The installation environment does not comply with international, national, or regional standards.
- Failure to comply with local laws, regulations, and standards when operating or maintaining the equipment.
- The installation area does not meet equipment requirements.
- Failure to follow operational instructions and precautions in the documentation.
- Failure to operate according to warning labels on the equipment or tools.
- Negligence, improper operation, or intentional damage.
- Failure to charge the equipment in a timely manner due to your reasons resulting in battery capacity loss or irreversible damage.
- Damage caused by you or a third-party company arbitrarily changing the usage scenarios of our company's equipment (e.g., mixing our battery packs with other batteries, using our battery packs with inverters or converters of other brands, etc.).
- Damage caused by customers or third-party companies who neither used the accessories provided with the package nor purchased and installed accessories of the same model.
- Unauthorized disassembly, replacement of equipment, or modification of software code leading to equipment damage.
- Equipment damage caused by force majeure (e.g., war, earthquake, fire, storm, lightning, flood, mudslide, etc.).
- Damage caused when the natural environment or external power parameters during actual operation of the equipment do not meet the standard requirements for equipment operation (e.g., excessively high or low operating temperatures).
- The equipment is stolen.
- Equipment damage after the warranty period has expired.

Safety Requirements

Danger

- **Overheating of the battery pack may cause fire or explosion. It is prohibited to expose the equipment to high-temperature environments or heat sources for extended periods (e.g., sunlight, fire sources, heaters, etc.).**

Danger

- Do not clean or soak the equipment with water, alcohol, oil, etc., to avoid electric leakage or battery fluid leakage.
- Do not strike or impact the equipment. In case of accidental impact, stop using the equipment immediately and contact your installer or sales agent. The equipment can only be used again after being inspected and evaluated by professionals.
- During operation, the temperature of the heat sink is high. Do not touch it.
- During operation, do not cover the decorative panel. Maintain a heat dissipation channel of 300–600mm to prevent high-temperature fires.

Caution

- Do not use the equipment with faults. If the equipment shows abnormalities (such as battery fluid leakage or deformation), contact your installer or sales agent immediately. Do not disassemble the equipment by yourself.
- It is recommended to keep a carbon dioxide fire extinguisher or ABC dry powder fire extinguisher at home.
- If the equipment cannot enter the charging state, contact your installer or sales agent immediately.

Prohibited Usage Scenarios:

- Connection to public infrastructure systems.
- Connection to emergency medical facilities.
- Connection to control equipment such as elevators.
- Any other similar scenarios, etc.

Chapter 2 Introduction to Energy Storage Systems

2.1 Product Model

SigenStor includes our company's single-phase inverters and battery packs, capable of storing and releasing electrical energy according to the management system requirements.

Model	Configured Inverter Model	Quantity of SigenStor BAT 5.0 configured	Quantity of SigenStor BAT 8.0 configured
SigenStor-5S-5	SigenStor EC 5.0 SP	1	0
SigenStor-5S-8	SigenStor EC 5.0 SP	0	1
SigenStor-5S-10	SigenStor EC 5.0 SP	2	0
SigenStor-5S-13	SigenStor EC 5.0 SP	1	1
SigenStor-5S-16	SigenStor EC 5.0 SP	0	2
SigenStor-6S-8	SigenStor EC 6.0 SP	0	1
SigenStor-6S-10	SigenStor EC 6.0 SP	2	0
SigenStor-6S-13	SigenStor EC 6.0 SP	1	1
SigenStor-6S-16	SigenStor EC 6.0 SP	0	2
SigenStor-6S-24	SigenStor EC 6.0 SP	0	3
SigenStor-8S-8	SigenStor EC 8.0 SP AU	0	1
SigenStor-8S-10	SigenStor EC 8.0 SP AU	2	0
SigenStor-8S-13	SigenStor EC 8.0 SP AU	1	1
SigenStor-8S-16	SigenStor EC 8.0 SP AU	0	2
SigenStor-8S-24	SigenStor EC 8.0 SP AU	0	3
SigenStor-8S-32	SigenStor EC 8.0 SP AU	0	4
SigenStor-8S-40	SigenStor EC 8.0 SP AU	0	5
SigenStor-8S-48	SigenStor EC 8.0 SP AU	0	6
SigenStor-10S-8	SigenStor EC 10.0 SP AU	0	1
SigenStor-10S-10	SigenStor EC 10.0 SP AU	2	0
SigenStor-10S-13	SigenStor EC 10.0 SP AU	1	1
SigenStor-10S-16	SigenStor EC 10.0 SP AU	0	2
SigenStor-10S-24	SigenStor EC 10.0 SP AU	0	3
SigenStor-10S-32	SigenStor EC 10.0 SP AU	0	4
SigenStor-10S-40	SigenStor EC 10.0 SP AU	0	5

Model	Configured Inverter Model	Quantity of SigenStor BAT 5.0 configured	Quantity of SigenStor BAT 8.0 configured
SigenStor-10S-48	SigenStor EC 10.0 SP AU	0	6
SigenStor-12S-8	SigenStor EC 12.0 SP AU	0	1
SigenStor-12S-10	SigenStor EC 12.0 SP AU	2	0
SigenStor-12S-13	SigenStor EC 12.0 SP AU	1	1
SigenStor-12S-16	SigenStor EC 12.0 SP AU	0	2
SigenStor-12S-24	SigenStor EC 12.0 SP AU	0	3
SigenStor-12S-32	SigenStor EC 12.0 SP AU	0	4
SigenStor-12S-40	SigenStor EC 12.0 SP AU	0	5
SigenStor-12S-48	SigenStor EC 12.0 SP AU	0	6

SigenStor includes our single-phase inverter, SigenStor EVDC, and battery packs, which can store and release electrical energy according to the management system requirements.

Model	Configured inverter model	Configured DC charging module model	Number of configured SigenStor BAT 5.0	Number of configured SigenStor BAT 8.0
SigenStor-8S-EV12-8	SigenStor EC 8.0 SP AU	SigenStor EVDC 12 7.5S2	0	1
SigenStor-8S-EV12-10	SigenStor EC 8.0 SP AU	SigenStor EVDC 12 7.5S2	2	0
SigenStor-8S-EV12-16	SigenStor EC 8.0 SP AU	SigenStor EVDC 12 7.5S2	0	2
SigenStor-8S-EV12-24	SigenStor EC 8.0 SP AU	SigenStor EVDC 12 7.5S2	0	3
SigenStor-8S-EV12-32	SigenStor EC 8.0 SP AU	SigenStor EVDC 12 7.5S2	0	4
SigenStor-8S-EV12-40	SigenStor EC 8.0 SP AU	SigenStor EVDC 12 7.5S2	0	5
SigenStor-8S-EV25-8	SigenStor EC 8.0 SP AU	SigenStor EVDC 25 7.5S2	0	1
SigenStor-8S-EV25-10	SigenStor EC 8.0 SP AU	SigenStor EVDC 25 7.5S2	2	0
SigenStor-8S-EV25-16	SigenStor EC 8.0 SP AU	SigenStor EVDC 25 7.5S2	0	2
SigenStor-8S-EV25-24	SigenStor EC 8.0 SP AU	SigenStor EVDC 25 7.5S2	0	3

Model	Configured inverter model	Configured DC charging module model	Number of configured SigenStor BAT 5.0	Number of configured SigenStor BAT 8.0
SigenStor-8S-EV25-32	SigenStor EC 8.0 SP AU	SigenStor EVDC 25 7.5S2	0	4
SigenStor-8S-EV25-40	SigenStor EC 8.0 SP AU	SigenStor EVDC 25 7.5S2	0	5
SigenStor-10S-EV12-8	SigenStor EC 10.0 SP AU	SigenStor EVDC 12 7.5S2	0	1
SigenStor-10S-EV12-10	SigenStor EC 10.0 SP AU	SigenStor EVDC 12 7.5S2	2	0
SigenStor-10S-EV12-16	SigenStor EC 10.0 SP AU	SigenStor EVDC 12 7.5S2	0	2
SigenStor-10S-EV12-24	SigenStor EC 10.0 SP AU	SigenStor EVDC 12 7.5S2	0	3
SigenStor-10S-EV12-32	SigenStor EC 10.0 SP AU	SigenStor EVDC 12 7.5S2	0	4
SigenStor-10S-EV12-40	SigenStor EC 10.0 SP AU	SigenStor EVDC 12 7.5S2	0	5
SigenStor-10S-EV25-8	SigenStor EC 10.0 SP AU	SigenStor EVDC 25 7.5S2	0	1
SigenStor-10S-EV25-10	SigenStor EC 10.0 SP AU	SigenStor EVDC 25 7.5S2	2	0
SigenStor-10S-EV25-16	SigenStor EC 10.0 SP AU	SigenStor EVDC 25 7.5S2	0	2
SigenStor-10S-EV25-24	SigenStor EC 10.0 SP AU	SigenStor EVDC 25 7.5S2	0	3
SigenStor-10S-EV25-32	SigenStor EC 10.0 SP AU	SigenStor EVDC 25 7.5S2	0	4
SigenStor-10S-EV25-40	SigenStor EC 10.0 SP AU	SigenStor EVDC 25 7.5S2	0	5
SigenStor-12S-EV12-8	SigenStor EC 12.0 SP AU	SigenStor EVDC 12 7.5S2	0	1
SigenStor-12S-EV12-10	SigenStor EC 12.0 SP AU	SigenStor EVDC 12 7.5S2	2	0
SigenStor-12S-EV12-16	SigenStor EC 12.0 SP AU	SigenStor EVDC 12 7.5S2	0	2
SigenStor-12S-EV12-24	SigenStor EC 12.0 SP AU	SigenStor EVDC 12 7.5S2	0	3

Model	Configured inverter model	Configured DC charging module model	Number of configured SigenStor BAT 5.0	Number of configured SigenStor BAT 8.0
SigenStor-12S-EV12-32	SigenStor EC 12.0 SP AU	SigenStor EVDC 12 7.5S2	0	4
SigenStor-12S-EV12-40	SigenStor EC 12.0 SP AU	SigenStor EVDC 12 7.5S2	0	5
SigenStor-12S-EV25-8	SigenStor EC 12.0 SP AU	SigenStor EVDC 25 7.5S2	0	1
SigenStor-12S-EV25-10	SigenStor EC 12.0 SP AU	SigenStor EVDC 25 7.5S2	2	0
SigenStor-12S-EV25-16	SigenStor EC 12.0 SP AU	SigenStor EVDC 25 7.5S2	0	2
SigenStor-12S-EV25-24	SigenStor EC 12.0 SP AU	SigenStor EVDC 25 7.5S2	0	3
SigenStor-12S-EV25-32	SigenStor EC 12.0 SP AU	SigenStor EVDC 25 7.5S2	0	4
SigenStor-12S-EV25-40	SigenStor EC 12.0 SP AU	SigenStor EVDC 25 7.5S2	0	5

SigenStor incorporates our three-phase inverters and battery packs, enabling energy storage and release as required by the management system.

Model	Configured inverter model	Number of configured SigenStor BAT 5.0	Number of configured SigenStor BAT 8.0
SigenStor-5T-8	SigenStor EC 5.0TP AU	0	1
SigenStor-5T-10	SigenStor EC 5.0TP AU	2	0
SigenStor-5T-13	SigenStor EC 5.0TP AU	1	1
SigenStor-5T-16	SigenStor EC 5.0TP AU	0	2
SigenStor-5T-24	SigenStor EC 5.0TP AU	0	3
SigenStor-10T-8	SigenStor EC 10.0TP AU	0	1
SigenStor-10T-10	SigenStor EC 10.0TP AU	2	0
SigenStor-10T-13	SigenStor EC 10.0TP AU	1	1
SigenStor-10T-16	SigenStor EC 10.0TP AU	0	2
SigenStor-10T-24	SigenStor EC 10.0TP AU	0	3
SigenStor-10T-32	SigenStor EC 10.0TP AU	0	4
SigenStor-10T-40	SigenStor EC 10.0TP AU	0	5
SigenStor-10T-48	SigenStor EC 10.0TP AU	0	6
SigenStor-15T-8	SigenStor EC 15.0TP AU	0	1

Model	Configured inverter model	Number of configured SigenStor BAT 5.0	Number of configured SigenStor BAT 8.0
SigenStor-15T-10	SigenStor EC 15.0TP AU	2	0
SigenStor-15T-13	SigenStor EC 15.0TP AU	1	1
SigenStor-15T-16	SigenStor EC 15.0TP AU	0	2
SigenStor-15T-24	SigenStor EC 15.0TP AU	0	3
SigenStor-15T-32	SigenStor EC 15.0TP AU	0	4
SigenStor-20T-10	SigenStor EC 20.0TP AU	2	0
SigenStor-20T-13	SigenStor EC 20.0TP AU	1	1
SigenStor-20T-16	SigenStor EC 20.0TP AU	0	2
SigenStor-20T-24	SigenStor EC 20.0TP AU	0	3
SigenStor-20T-32	SigenStor EC 20.0TP AU	0	4
SigenStor-20T-40	SigenStor EC 20.0TP AU	0	5
SigenStor-20T-48	SigenStor EC 20.0TP AU	0	6
SigenStor-25T-10	SigenStor EC 25.0TP AU	2	0
SigenStor-25T-13	SigenStor EC 25.0TP AU	1	1
SigenStor-25T-16	SigenStor EC 25.0TP AU	0	2
SigenStor-25T-24	SigenStor EC 25.0TP AU	0	3
SigenStor-25T-32	SigenStor EC 25.0TP AU	0	4
SigenStor-25T-40	SigenStor EC 25.0TP AU	0	5
SigenStor-25T-48	SigenStor EC 25.0TP AU	0	6
SigenStor-30T-16	SigenStor EC 30.0TP AU	0	2
SigenStor-30T-24	SigenStor EC 30.0TP AU	0	3
SigenStor-30T-32	SigenStor EC 30.0TP AU	0	4
SigenStor-30T-40	SigenStor EC 30.0TP AU	0	5
SigenStor-30T-48	SigenStor EC 30.0TP AU	0	6

Tips

The SigenStor EVDC 12 series models support upgrading the rated output power to 25kW. For specific operations, please refer to the [FAQs](#).

2.2 Appearance Introduction

2.2.1 Appearance and Dimensions

Without SigenStor EVDC series

Tips

The preceding figure takes two SigenStor BATs as an example to show the appearance.

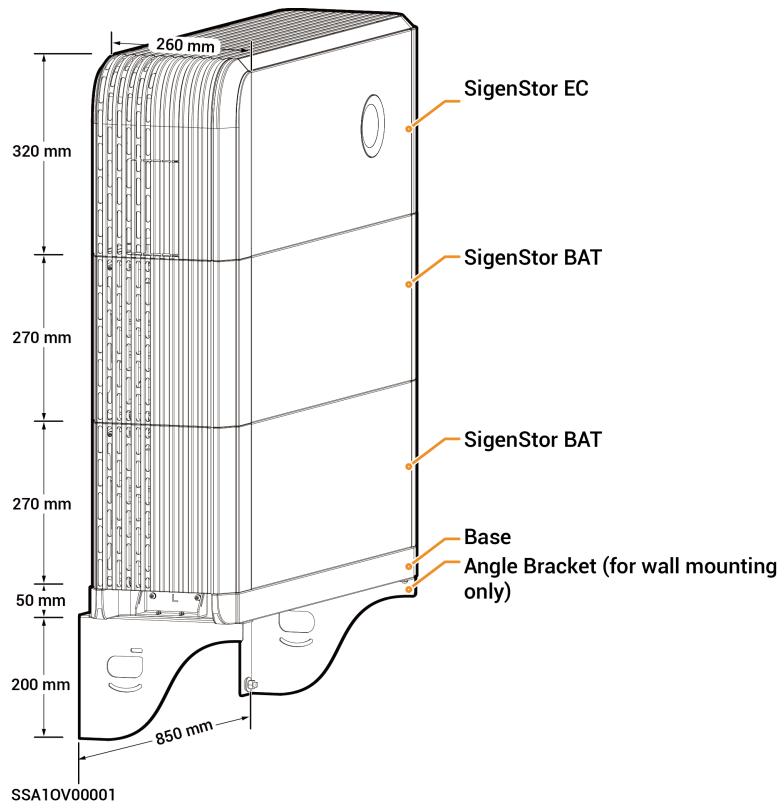

With SigenStor EVDC Series

Tips

The preceding figure takes one SigenStor BAT as an example to show the appearance.

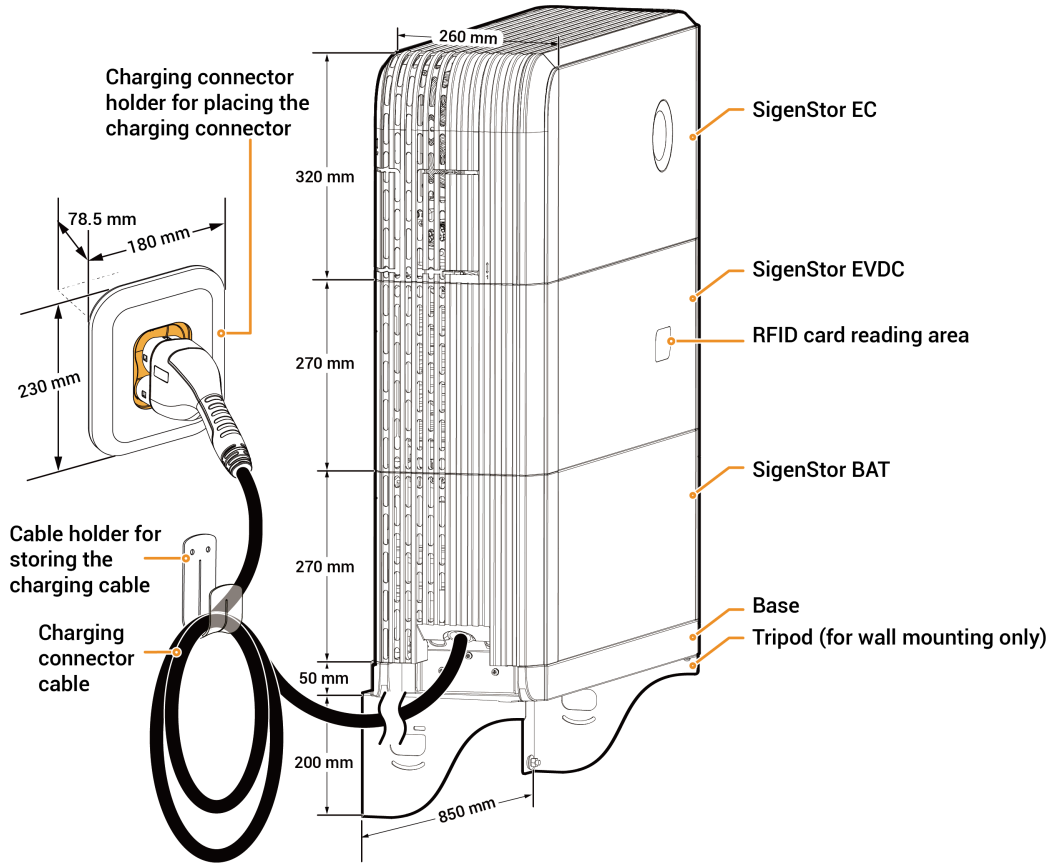

SSA10V00036

2.2.2 Port Introduction

SigenStor EC (5.0, 6.0) SP

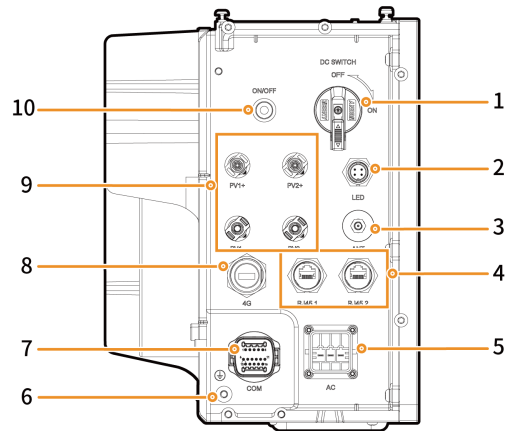

SSA10V00030

No.	Name	Marking
1	DC Switch	DC SWITCH
2	Decorative cover light strip connector	LED
3	Antenna Interface	ANT
4	Ethernet port	RJ45 1/ RJ45 2
5	AC output interface	AC
6	Grounding screw	-
7	RS485 communication interface	COM
8	Sigen CommMod interface	4G
9	DC input interface	PV1+/PV2+/ PV1-/PV2-
10	Switch button	ON/OFF

SigenStor EC (5.0–30.0) TP AU

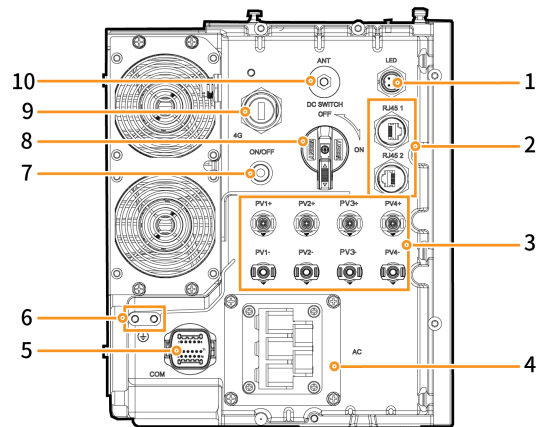

SSA10V00009

S/N	Name	Marking
1	Decorative cover strip light connector	LED
2	Network interface	RJ45 1/ RJ45 2
3	DC input interface	PV1+/PV2+/PV3+/PV4+/PV1-/ PV2-/PV3-/PV4-
4	AC output interface	AC
5	Communication interface	COM
6	Grounding screw	-
7	Switch button	ON/OFF
8	DC switch	DC SWITCH
9	Sigen CommMod interface	4G
10	Antenna interface	ANT

SigenStor EC-(8.0-12.0) SP AU

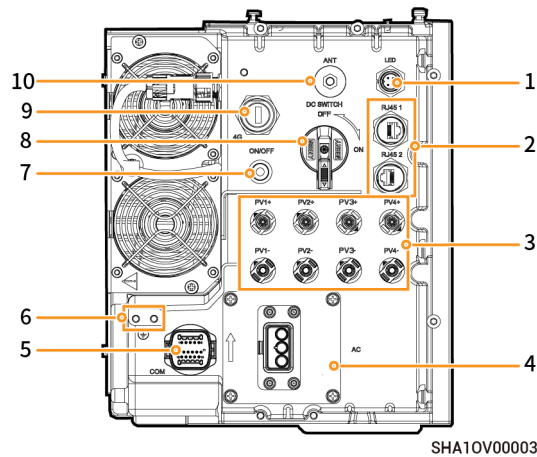

S/N	Name	Marking
1	Trim lighting strip interface	LED
2	Network interface	RJ45 1/ RJ45 2
3	DC input port	PV1+/PV2+/ PV3+/PV4+/ PV1-/PV2- /PV3-/PV4-
4	AC output port	AC
5	Communication interface	COM
6	Grounding screw	-
7	Switch button	ON/OFF
8	DC switch	DC SWITCH
9	Sigen CommMod interface	4G
10	Antenna interface	ANT



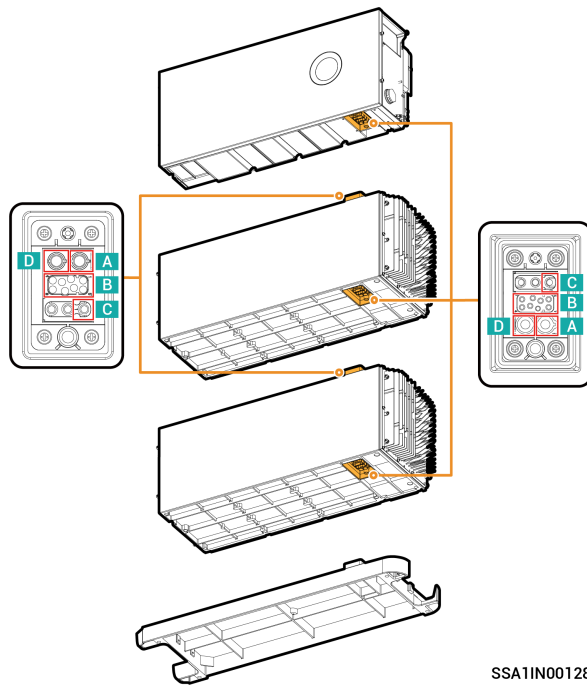



Module blind-mate connector



SSA1IN00128

No.	Meaning
A	BAT-
B	Communication Interface
C	PE
D	BAT+

2.2.3 Label Instructions

Symbol	Definition
	<p>Danger! High Voltage</p> <p>The equipment carries high voltage when powered on. Do not open the enclosure while the equipment is operational. All maintenance and repair work must be performed by qualified professional electrical technicians.</p>
	<p>Warning! Life Hazard</p> <p>Potential hazards exist during equipment operation. Proper protective measures must be taken when operating the device.</p>
	<p>After power-off, internal components experience discharge delay. Wait for 10 minutes as labeled until complete discharge is achieved.</p>
	<p>Warning! Burn Hazard</p> <p>High temperatures exist on the surface of heat dissipation areas. Do not touch during operation to avoid burns.</p>
	<p>Please refer to the manual for device operation.</p>
	<p>Grounding symbol</p>

2.3 Supported grid power supply modes

SigenStor-(5S, 6S) Series & SigenStor-(8S-12S) Series

- The grid supply methods supported include TN-S, TN-C, TN-C-S, and TT.
- When TT is used as the power supply technique for the power grid, the voltage between N and PE is required to be < 30 V.

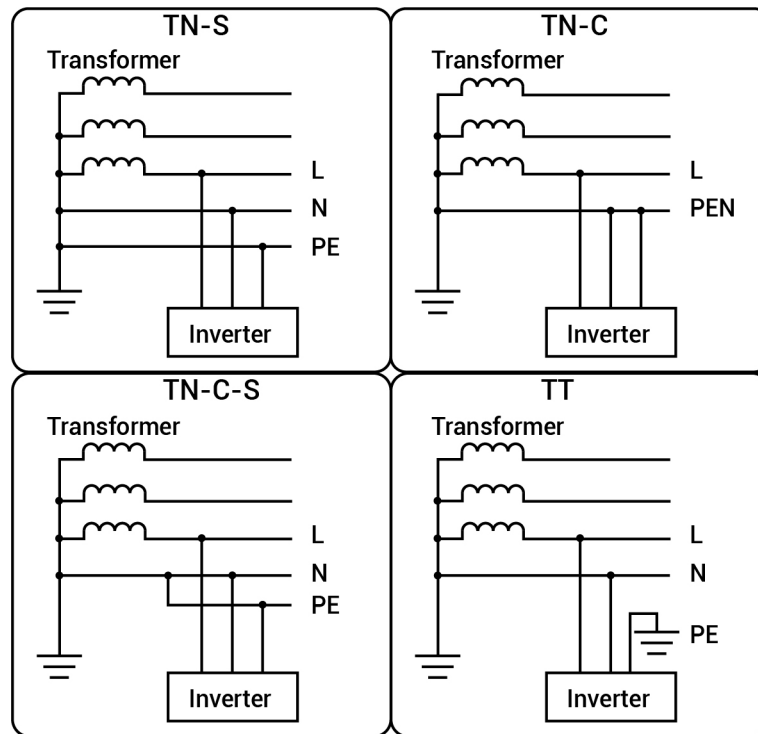

SVA10V00002

SigenStor-(5T-30T) Series

- The grid supply methods supported include TN-S, TN-C, TN-C-S, TT and IT.
- When TT is used as the power supply technique for the power grid, the voltage between N and PE is required to be < 30 V.

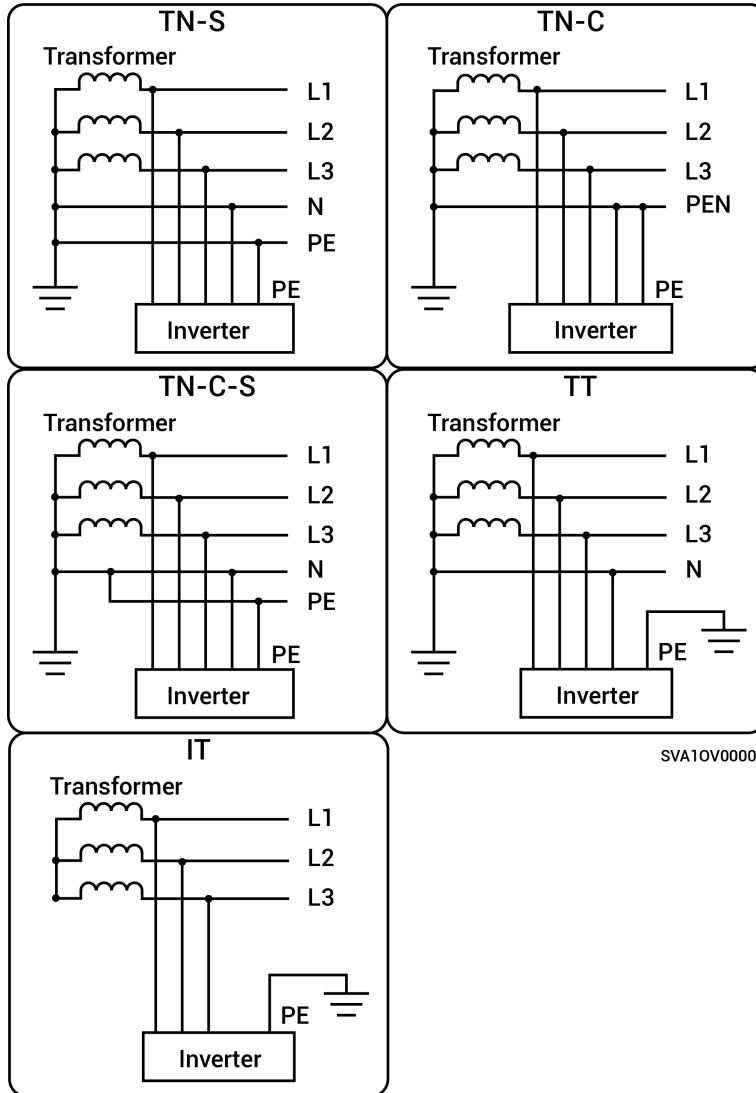

2.4 Typical Networking Introduction

- SigenStor can be used for Home energy storage system. The Home energy storage system consists of photovoltaic panels^[1], inverters, battery packs, master control switches, Gateway, loads, power grids, etc.
- The main function of Home energy storage system is to store the direct current generated by photovoltaic panels into battery packs. Or alternatively, the electricity in the photovoltaic system and the battery pack can be converted into alternating current for use by the load or incorporated into the grid.

Note [1]: PV panels with functional grounding cable connected cannot be used.

Tips

Under backup power networking, the duration of off-grid operation of the backup power load is related to the power supply capacity of the PV storage system. If there is an abnormality in the power supply of the PV storage system during off-grid operation (including but not limited to abnormal PV power generation, insufficient battery power, and abnormal power supplies to the diesel generator), the backup power load will still be unable to operate.

Networking Diagram (Whole Home Backup)

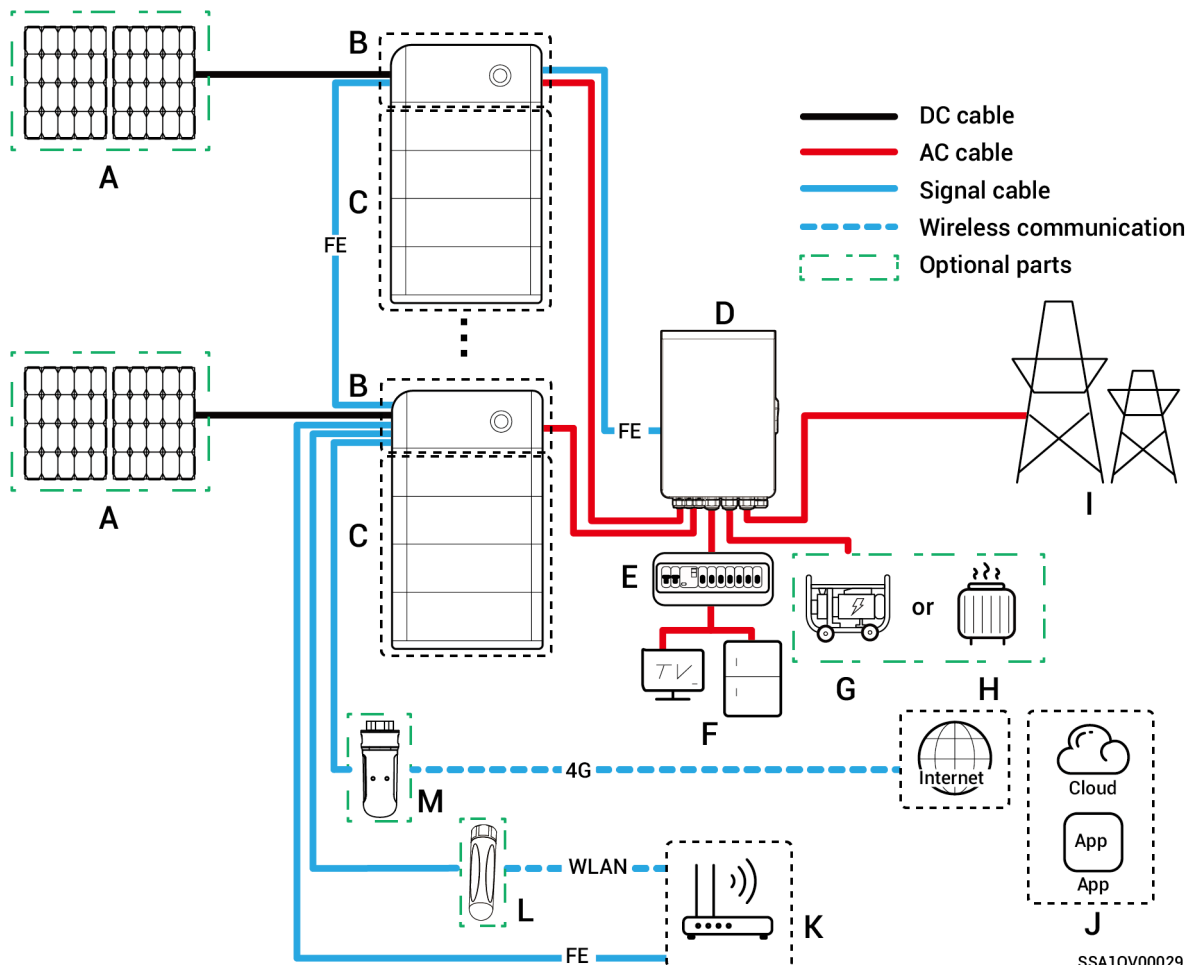

SSA10V00029

No.	Description	No.	Description	No.	Description
A	PV panel	B	SigenStor EC	C	SigenStor BAT
D	Gateway	E	Backup Distribution panel	F	Backup household load
G	Diesel generator	H	Smart load	I	Power grid
J	mySigen	K	Router	L	Antenna
M	CommMod				

Tips

- No more than 20 SigenStor units can be cascaded.
- If F (backup household loads) experiences leakage, it may pose a risk of electric shock. In order to avoid this hazard, a residual current device (RCD) must be installed between the D (Gateway) and the F (backup household loads).
- As a backup energy source for long-term off-grid applications, the diesel generator can work in tandem with the Gateway to provide a smooth transition between PV, storage and diesel power generation.
- All the power equipment in the owner's home can be connected as smart loads. To ensure that this product maximizes the benefits to users, it is recommended that the high-power equipment be connected as smart loads (heat pumps, pool heaters, clothes dryers, immersion heaters, etc.), which can be cut off when the energy storage system has low power. Other low-power equipment are connected as home loads (lights, routers, etc.) The maximum power for an immersion heater should be ≤ 17.6 kW/80 A.
- It is recommended to use Fast Ethernet and WLAN for communication with inverters. If 4G communication is used, you must purchase Sigen CommMod separately. When free 4G traffic of CommMod runs out, users must top up their accounts or replace an SIM card.

Networking Diagram (Partial Home Backup)

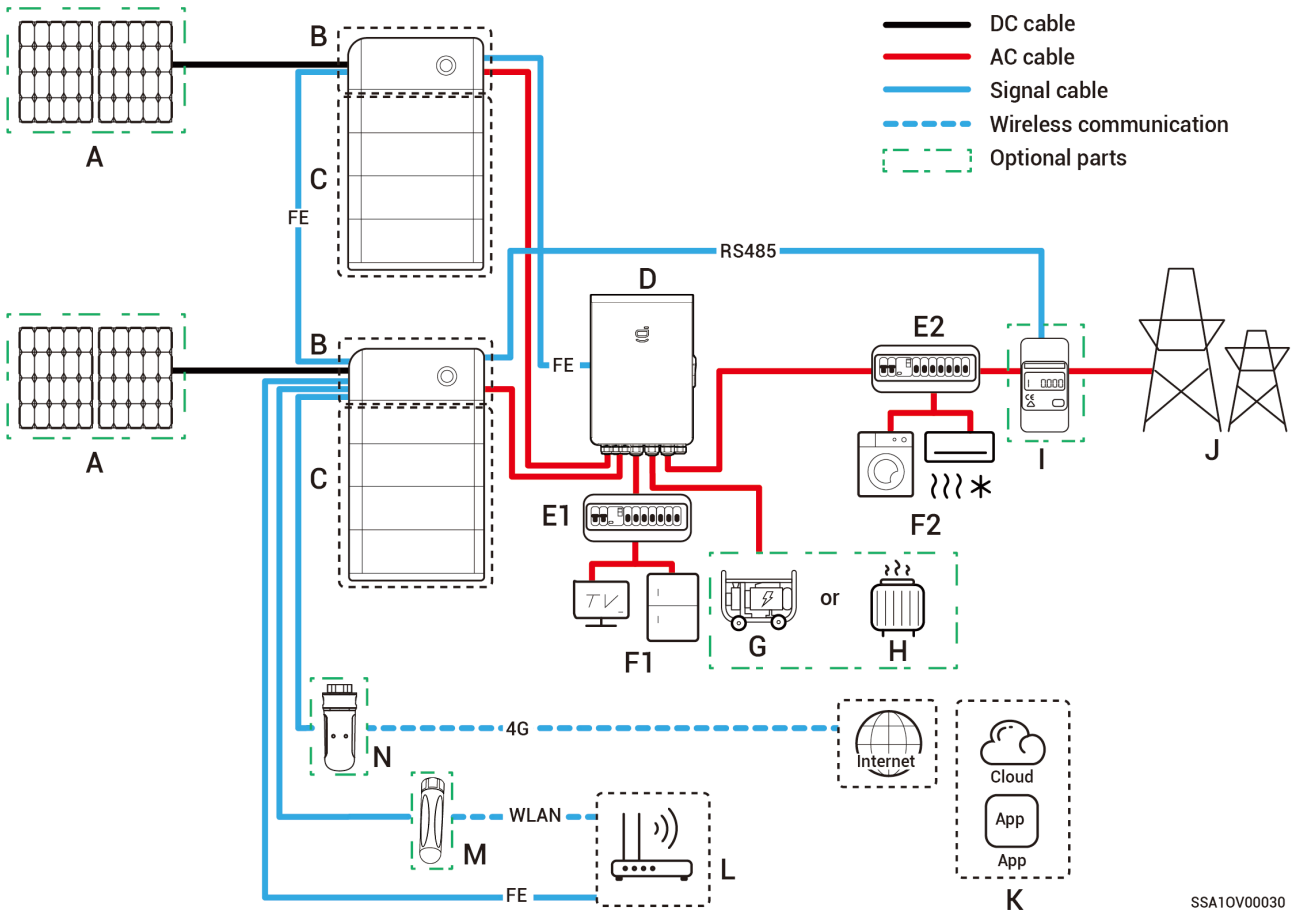

SSA10V00030

No.	Description	No.	Description	No.	Description
A	PV panel	B	SigenStor EC	C	SigenStor BAT
D	Gateway	E1	Backup power distribution unit	E2	Non-backup power distribution unit
F1	Backup household load	F2	Non-backup household load	G	Diesel generator
H	Smart Load	I	Power Sensor	J	Power Grid
K	mySigen	L	Router	M	Antenna rod
N	CommMod				

Tips

- No more than 20 SigenStor units can be cascaded.
- If E2 (non-backup distribution panel) features leakage protection, it is recommended that the rated residual operating current be greater than or equal to the number of inverters \times 100 mA.
- If F1 (backup household loads) experiences leakage, it may pose a risk of electric shock. In order to avoid this hazard, a residual current device (RCD) must be installed between the D (Gateway) and the F1 (backup household loads).

Tips

- As a backup energy source for long-term off-grid applications, the diesel generator can work in tandem with the Gateway to provide a smooth transition between PV, storage and diesel power generation.
- All the power equipment in the owner's home can be connected as smart loads. To ensure that this product maximizes the benefits to users, it is recommended that the high-power equipment be connected as smart loads (heat pumps, pool heaters, clothes dryers, immersion heaters, etc.), which can be cut off when the energy storage system has low power. Other low-power equipment are connected as home loads (lights, routers, etc.) The maximum power for an immersion heater should be ≤ 17.6 kW/80 A.
- Power sensor has the function of data acquisition for grid connection points enables zero-power grid connection. For partial home backup, Power sensor does not need to be configured. For partial backup power and zero-power grid connection control networking, Power sensor is configured.
- It is recommended to use Fast Ethernet and WLAN for communication with inverters. If 4G communication is used, you must purchase Siggen CommMod separately. When free 4G traffic of CommMod runs out, users must top up their accounts or replace an SIM card.

Network Diagram (Non-backup Networking)

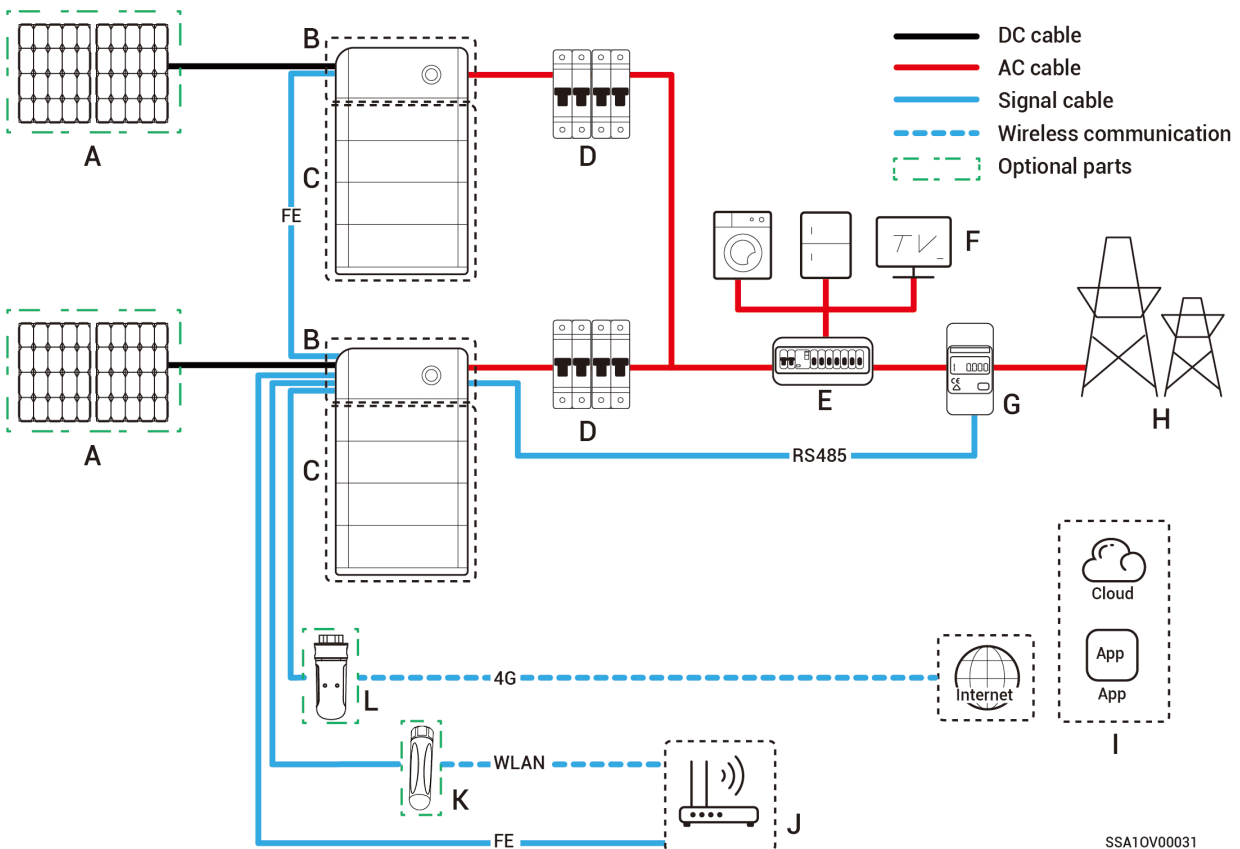

No.	Description	No.	Description	No.	Description
A	PV panel	B	SigenStor EC	C	SigenStor BAT
D	AC switch	E	Distribution panel	F	Household load
G	Power sensor	H	Power grid	I	mySigen
J	Router	K	Antenna	L	CommMod

Tips

- No more than 20 SigenStor units can be cascaded.
- SigenStor-(5S, 6S) Series: the rated voltage of the AC switch connected to each inverter should be ≥ 240 Va.c. and the rated current is 40 A.
- SigenStor-(8S–12S) Series: the rated voltage of the AC switch connected to each inverter should be ≥ 240 Va.c., and the rated current is recommended:
 - SigenStor-8S Series: The rated current is 50 A
 - SigenStor-(10S-12S) Series: The rated current is 60 A
- SigenStor-(5T–30T) Series: the rated voltage of the AC switch connected to each inverter should be ≥ 380 Va.c., and the rated current is recommended:
 - SigenStor-5T Series: The rated current is 25 A
 - SigenStor-(10T-15T) Series: The rated current is 32 A
 - SigenStor-20T Series: The rated current is 40 A
 - SigenStor-25T Series: The rated current is 50 A
 - SigenStor-30T Series: The rated current is 63 A
- If E (distribution panel) features leakage protection, it is recommended that the rated residual operating current be greater than or equal to the number of inverters \times 100 mA.
- It is recommended to use Fast Ethernet and WLAN for communication with inverters. If 4G communication is used, you must purchase Sigen CommMod separately. When free 4G traffic of CommMod runs out, users must top up their accounts or replace an SIM card.
- SigenStor-(5S, 6S) & SigenStor-(8S–12S) Series: the rated voltage of the AC switch of the distribution panel should be not less than 240 Va.c., and the rated current is recommended, that is, not less than the maximum output current of an inverter \times the number of inverters in parallel connection \times 1.25^[1].
- SigenStor-(5T–30T) Series: the rated voltage of the AC switch of the distribution panel should be not less than 380 Va.c., and the rated current is recommended, that is, not less than the maximum output current of an inverter \times the number of inverters in parallel connection \times 1.25^[1].

Note [1]: The maximum output current of an inverter can be found in its respective data sheet.

Chapter 3 Site Selection Requirements

Tips

- The equipment supports both indoor and outdoor installation. Installation must comply with the instructions in this section and local laws and regulations.
- Before installing the equipment, please carefully read the following installation requirements. If functional abnormalities, damage, or even personal safety accidents occur during operation due to failure to comply with these requirements, our company will not bear any responsibility.
- During actual installation, the selected location must meet local fire safety, environmental protection, and other regulations. The specific installation location plan shall be determined by the installer or EPC (Engineering, Procurement, Construction).

Installation Environment Requirements

- Do not install the equipment in environments with smoke, flammability, explosiveness, or corrosiveness.
- Avoid installing the equipment in environments exposed to direct sunlight, rain, water accumulation, snow accumulation, sand, or dust. It is recommended to install the equipment in a sheltered location. If the area is prone to natural disasters such as floods, mudslides, earthquakes, or typhoons, preventive measures must be taken during installation.
- Do not install the equipment in environments with strong electromagnetic interference.
- The temperature and humidity of the installation environment must meet the equipment requirements.
- The equipment should be installed in areas $\geq 500\text{m}$ away from high-salt or high-acid corrosion sources (including but not limited to coastal areas, thermal power plants, chemical plants, smelters, coal plants, rubber plants, electroplating plants, etc.).
- In areas with good marine environments (such as Norway, where near-shore salinity ≤ 28 psu), the installation distance from the coastline can be appropriately relaxed to $\geq 200\text{m}$.
- If the equipment's exterior surface is damaged, promptly repaint the equipment.

Installation Location Requirements

- Do not tilt or invert the equipment; ensure it is installed horizontally.
- Do not install the equipment in locations easily accessible to children.
- Do not install the equipment near fire sources or in damp locations.
- The equipment generates noise during operation; install it away from daily work and living areas.
- Do not install the equipment in enclosed, poorly ventilated areas without firefighting facilities or where firefighters cannot easily access.
- The equipment generates heat during operation. If installed indoors, ensure proper ventilation and prevent indoor temperature from rising more than 3°C due to equipment operation to avoid performance degradation.
- Do not install the equipment in mobile scenarios such as RVs, cruise ships, or trains.

Configuration SigenStor EVDC Series

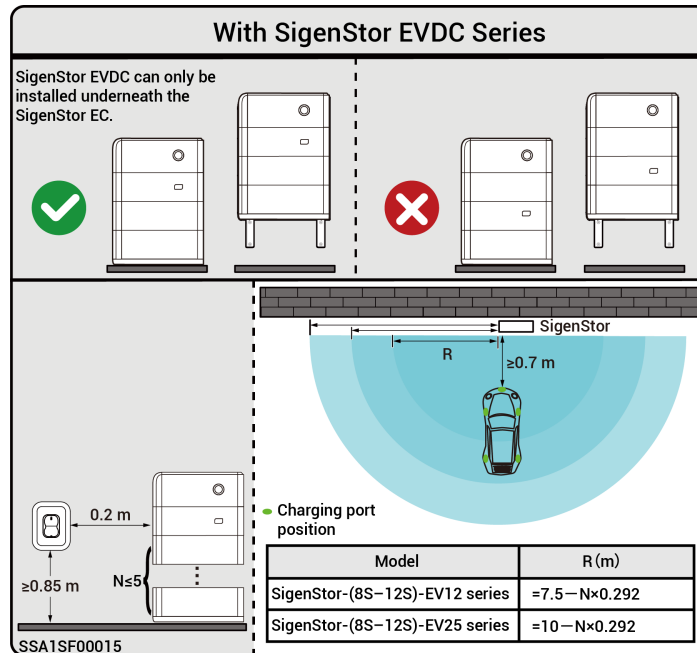

Tips

- For SigenStor EVDC series, install near parking spaces, and refer to the diagram for installation distance.
- Actual distances may vary under different installation conditions; the diagram is for reference only.
- The equipment supports a maximum operating temperature range of -20°C to 55°C , with an optimal range of $10^{\circ}\text{C} \leq T \leq 35^{\circ}\text{C}$ recommended.
- When the battery pack temperature is below 0°C , immediate charging is not possible, and the battery pack (the built-in heating module can be automatically enabled) will activate the heating feature automatically. The best charging performance of the battery can be achieved after heating for less than 2h. The heating feature will consume power.
- At a temperature $> 40^{\circ}\text{C}$, the operation of the equipment may trigger a power derating that prevents the equipment from operating optimally. The higher the temperature, the shorter the service life of the equipment.

Chapter 4 Equipment Installation and Wiring

- Equipment installation and wiring can only be performed by installation personnel approved by our company. For specific operation methods, please refer to the "Installation Guide" for the corresponding model.
- All included components are personal assets of the owner and should be properly kept.

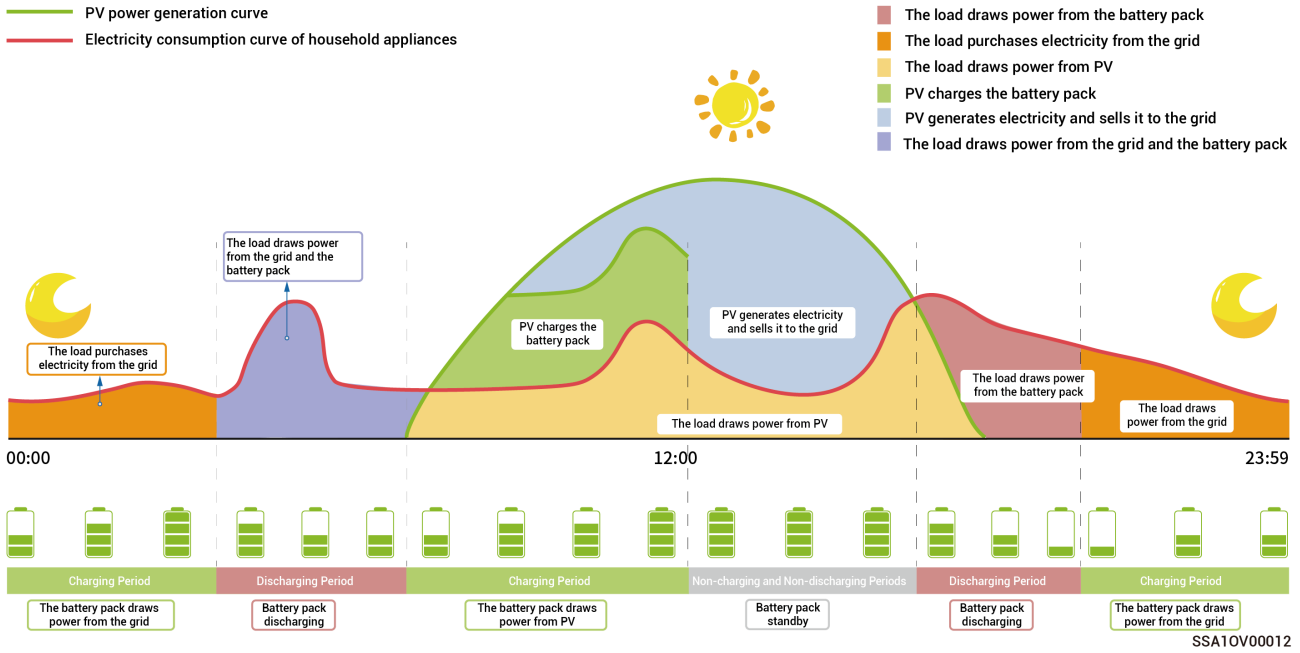

Fully Fed-in to Grid Mode

- You can sell excess energy back to the grid and earn credits on your energy bill.
- In the daytime, when the PV power is greater than the maximum output capacity of the inverter, the inverter maintains the maximum output while storing excess energy in the batteries. When the PV power is lower than the maximum output capacity of the inverter or there is no PV power in the nighttime, the batteries are discharged to ensure that the inverter maximizes the output.

Remote EMS Mode

After setting to this mode, a third-party EMS dispatch company will be allowed to set the relevant parameters of the power station and products. Do not enter or exit this mode without the installer's confirmation.

Load Shedding Mode

In areas with frequent power outages, you can add your region and schedule in this mode, and the system will fully charge the battery in advance as scheduled, ensuring that you have battery power available to supply the load during outages. (currently only supported in South Africa)

VPP Scheduling-evergen Mode

Once registered with the VPP, your storage system will join the smart dispatching network. The App will show and auto-enable this mode.

5.2 Power Station Backup Power Setting

Tips

- If Gateway is not configured, please ignore this section.
- Users can manually set this parameter according to the power interruption frequency of their regions and leave time.

If there is a gateway in your networking, you can manually set the "Backup Reserve" value in the mySigen App. In grid connection mode, the battery stops discharging when the backup power SOC setting is reached. In the event of grid power outage, the backup power becomes available. For example, the backup power SOC is set in Self-Consumption Mode.

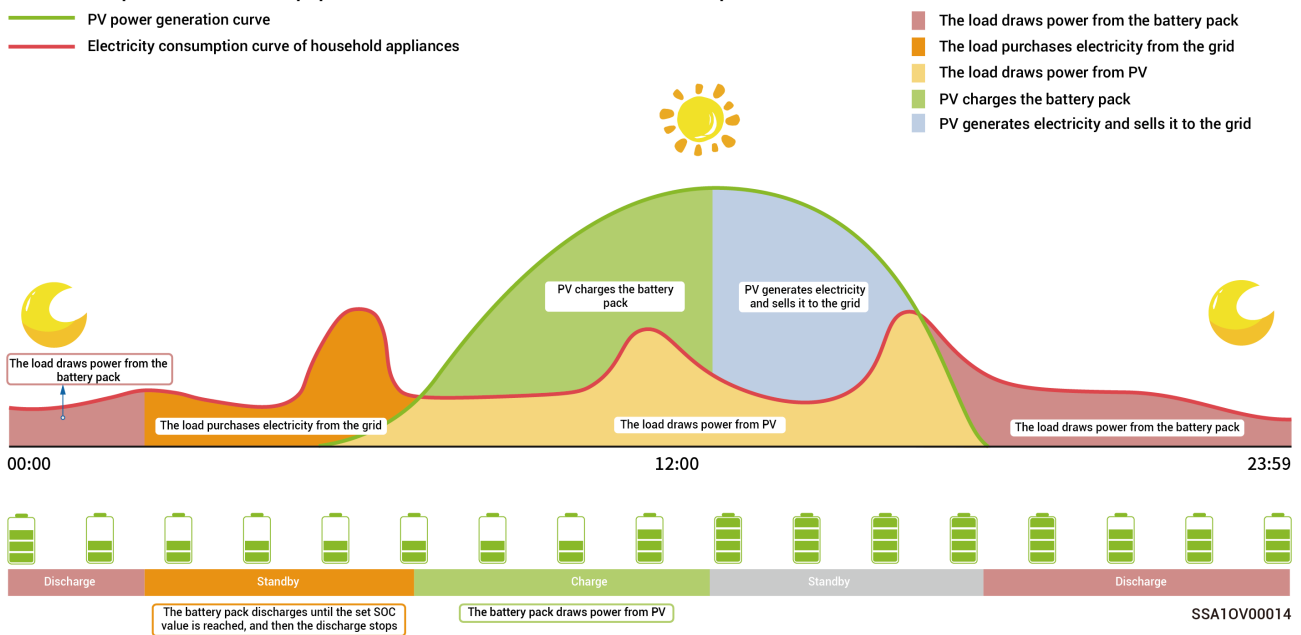

5.3 Peak Shaving Control Mode

- The electricity bill in some regions is calculated as follows: Total electricity bill = Cost at peak power + cost for electricity usage + other costs. Wherein, peak power refers to the maximum power imported from the grid. This mode is suitable for areas with peak and valley electricity prices and significant price differences.
- The Peak Shaving function can be used with all working modes, configuring the maximum peak power drawn from the grid to reduce the maximum peak power drawn from the grid during peak periods, thereby lowering the electricity bill.

Example 1: Self-Consumption Mode Settings for Peak Shaving

Assume that the peak shaving SOC is set to 50% and the maximum peak power is 2kW. Because Total electricity bill = Cost at peak power + cost for electricity usage + other costs. Wherein, peak power refers to the maximum power imported from the grid. After Self-Consumption Mode is set to Peak Shaving, the power purchased from the grid drops from 5 kW to 2 kW, so the total electricity bill is reduced.

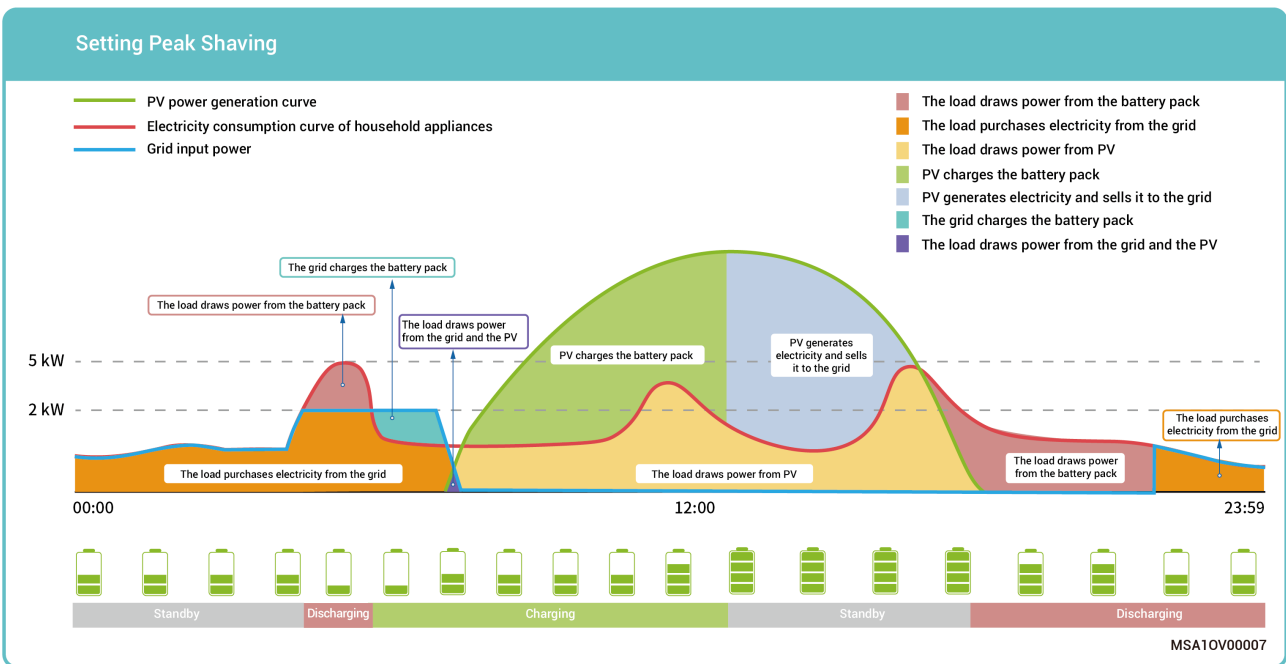
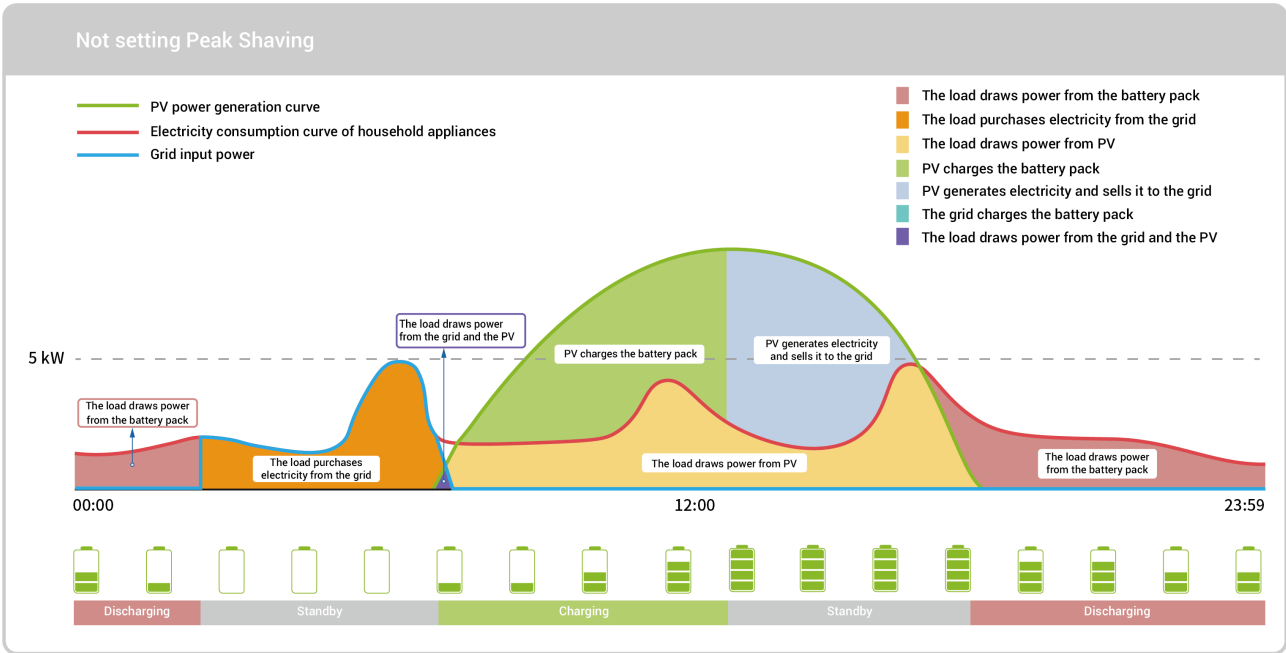

Example 2: Time-based Control Mode Settings for Peak Shaving

Assume that the peak shaving SOC is set to 50% and the maximum peak power is 2kW. Because Total electricity bill = Cost at peak power + cost for electricity usage + other costs. Wherein, peak power refers to the maximum power imported from the grid. After Time-based Control Mode is set to Peak Shaving, the power purchased from the grid drops from 5 kW to 2 kW, so the total electricity bill is reduced.

Not setting Peak Shaving

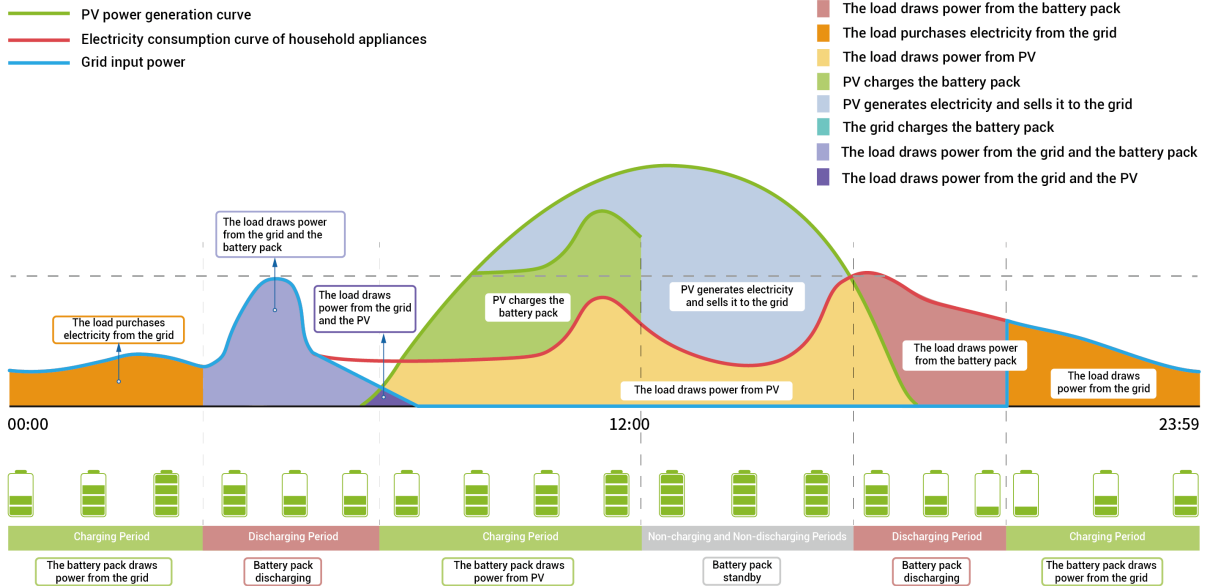

Setting Peak Shaving

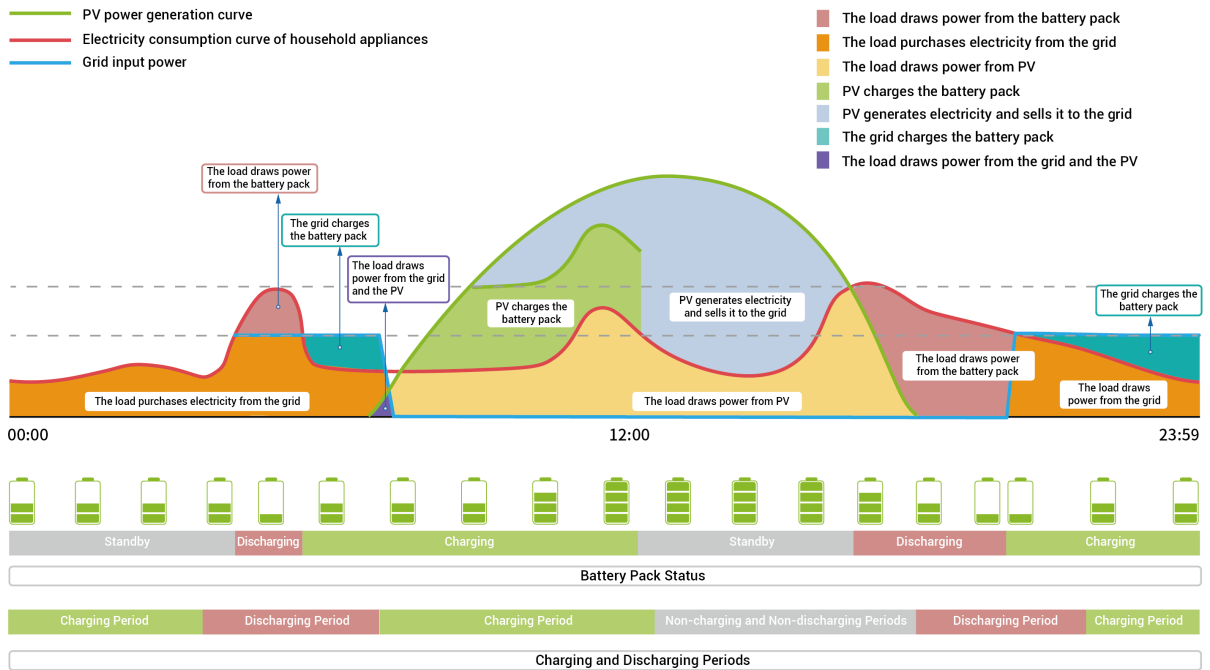

MSA10V00008

5.4 LED indicator status

SigenStor EC indicators

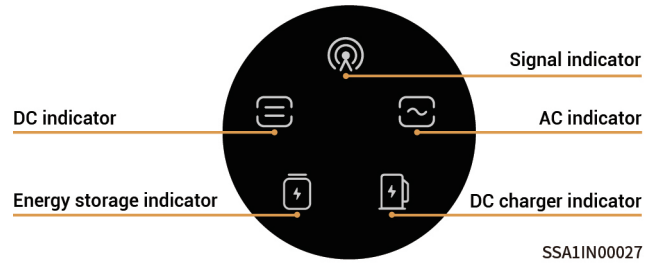

Indicator	Color	State	Description
		Always on	The DC side is connected but not running.
		Always on	The DC side is running.
		-	The DC side is not connected.
		Flash	The DC side is faulty.
		Always on	Inverter failure.
		Always on	The AC side is connected but not running.
		Always on	Grid-connected operation.
		Always on	Off-grid operation.
		-	The AC side is not connected.
		Flash	Off-grid overload operation.
		Flash	The AC side is faulty.
		Always on	Inverter failure.
		Always on	All SigenStor BATs are connected but not running.
		Flash	SigenStor BAT is charging.
		Flash	SigenStor BAT is discharging.
		-	All SigenStor BATs lie dormant.
		Flash	Some SigenStor BATs are faulty.
		Always on	All SigenStor BATs are faulty.
		Off	The management system is not connected.
		Flash	Connected to local App.
		Always on	Connected to the management system using an FE or WLAN.
		Always on	Connected to the management system over 4G.
		Flash	Insufficient traffic for Sigen CommMod.

5.5 mySigen App Query and Settings

The App can be downloaded in the following two ways. For details, please refer to "*mySigen App User Manual*".



SSA1CM00014

Chapter 6 System Maintenance

6.1 Routine Maintenance

To ensure long-term optimal performance of the equipment, it is recommended to perform routine maintenance as described in this section.

Inspection Items	Inspection Methods	Power Off Required	Maintenance Interval
System Cleaning	Regularly check decorative covers for obstructions and dust/dirt accumulation. If found, clean them. Prohibit using tools that may cause electric shock or insulation damage (e.g., steel brushes) during cleaning.	Yes	Once every 3 months.
System operating status	<ul style="list-style-type: none"> ● Check whether the equipment appearance is damaged or deformed. ● Listen for any abnormal sounds during equipment operation. ● During equipment operation, verify whether all parameters are set correctly 	No	Once every 6 months.

6.2 System Power Off/On

Danger

High voltage, hazardous: When operating the equipment, please wear protective gear such as insulated gloves, insulated shoes, and safety helmets. Do not wear conductive accessories like metal bracelets, rings, or necklaces.

System power-off

1. Power the equipment off in the App or manually.

App operation:

Tap "Setting" in mySigen App to turn on/off the device.

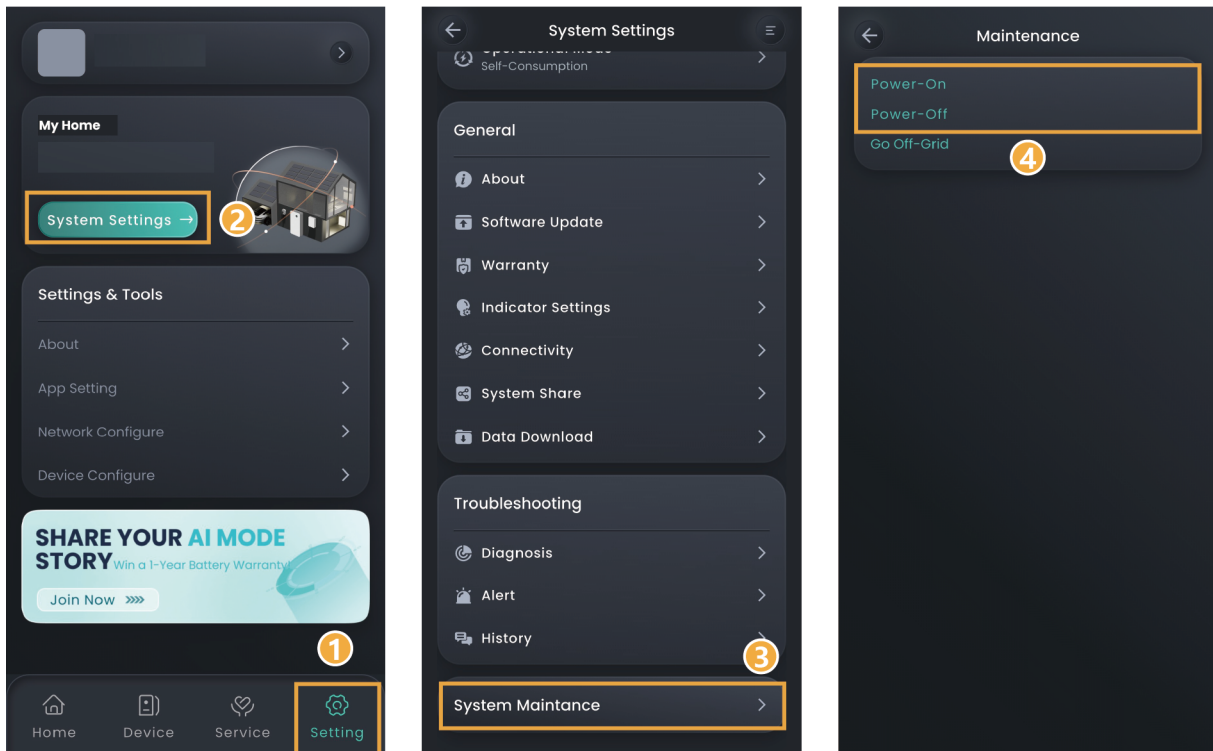

MSA1CM00071

Manual operation:

Follow the steps shown to remove the side and top decorative cover, and press the ON/OFF switch button.

Tips

Press and hold for more than 3s to turn on or off the power; an interval of more than 10s is needed between power-on and power-off.

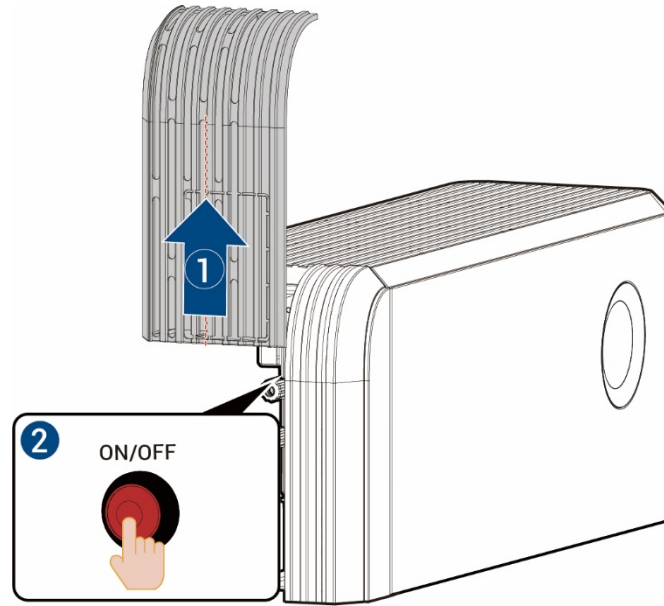

SSA1IN00030

Tips

Major firmware upgrades can fail if the equipment is not connected to the internet for an extended period of time. When your device is not connected to the internet, the system issues periodic notifications. If the disconnection persists beyond 90 consecutive days, the system will automatically engage in safe operating mode for safety compliance. Reconnect to the internet immediately. For unresolved issues, feel free to contact us.

1. Turn off the switch connected to the equipment in the backup power distribution panel.
2. Turn DC SWITCH on the equipment to the OFF position.
3. After all LED indicators on the equipment go off, wait for the corresponding time as indicated on the label on the equipment before proceeding.

Warning

There is residual current and the equipment is hot immediately after the equipment is powered off. Operating the equipment immediately upon power off may lead to electric shock or burns.

System power-on

1. Turn DC SWITCH on the equipment to the ON position.
2. Turn on the switch connected to the equipment in the backup power distribution panel.
3. Power the equipment on in the App or manually. For details, see Step 1 in System power-off.

6.3 Low SOC

The self-discharge characteristic of battery pack will cause power loss. If the equipment is not charged for a long time, it may be damaged due to overdischarge of power. When the battery is low, charge the equipment in time. Under normal circumstances, the equipment can charge itself according to the running condition. If the equipment cannot be charged, please contact your sales agent in time and deal with it within the specified time. If the battery capacity is lost or irreversible damage is caused due to the delay, the company will not be liable.

- When the battery power is greater than or equal to 10%, charge within 30 days
- When the battery power is less than or equal to 0% and less than 10%, charge within 7 days

Scenarios that may cause a charge failure (including but not limited to) :

- The PV side has no input, and the power grid side is powered off for a long time.
- The equipment is faulty.
- Parameters are not set correctly.

6.4 Emergency Treatment

Fire emergency measures

Danger

- Ensure safety first, then power off the device or disconnect the main power switch.
- High temperatures may cause battery pack deformation, damage, electrolyte leakage, or even toxic gas release. Keep a safe distance and wear protective gear.
- For small fires, use carbon dioxide or ABC dry powder fire extinguishers.
- If the fire shows signs of spreading, evacuate the building or equipment area immediately and call the fire department. Do not re-enter the burning building.
- Firefighters should avoid contact with high-voltage components during firefighting to prevent electric shock hazards.
- After extinguishing the fire, do not use the device. Contact your installer or sales agent.

Flood emergency measures

Danger

- Ensure safety first, then power off the device or disconnect the main power switch.
- If the battery pack is submerged, do not touch it to avoid electric shock hazards.
- After floodwaters recede, do not use the device. Contact your installer or sales agent.

Battery pack abnormal emergency measures

Danger

- When the battery pack exhibits abnormal odors, electrolyte leakage, overheating, etc., do not approach or touch it, and immediately contact professionals for handling. Professionals must wear protective equipment such as goggles, rubber gloves, gas masks, and protective clothing to ensure their own safety.
- The electrolyte is corrosive, and contact may cause skin irritation or chemical burns. If accidentally exposed to the electrolyte, take the following measures immediately:
 - Inhalation: Evacuate the contaminated area, ensure fresh air circulation, and seek medical help immediately.
 - Eye contact: Rinse eyes with plenty of clean water for ≥ 15 minutes, avoid rubbing, and seek medical help immediately.
 - Skin contact: Wash the affected area thoroughly with soap and water, and seek medical help immediately.
 - Ingestion: Induce vomiting and seek medical help immediately.
- Do not continue using the abnormal battery pack; contact your installer or sales agent.

Battery pack drop or impact emergency measures

- If obvious odors, smoke, or fire occur, stay away from the equipment immediately and contact professionals for handling.
- Do not use the battery pack after it has been dropped or impacted; contact your installer or sales agent.

Chapter 7 Technical Parameters

Parameter Name	SigenStor 5S-(5-16)	SigenStor 5S-(8-24)	Sigen-Stor 5T Series	Sigen-Stor 10T Series	Sigen-Stor 15T Series	Sigen-Stor 20T Series	Sigen-Stor 25T Series	Sigen-Stor 30T Series
Pollution degree	PD2, PD3	PD2, PD3	PD3	PD3	PD3	PD3	PD3	PD3
Back feed current	0 A	0 A	0 A	0 A	0 A	0 A	0 A	0 A
Inrush current	21.7 A	28.7 A	7.25	14.49	21.74	31.88	39.86	43.48
Max. output overcurrent protection	32.5 A	43.0 A	8.36	16.71	25.07	33.43	41.78	50.14
Max. output fault current	65.0 A	86.0 A	76	76	76	76	76	76

For other device parameters, please refer to the corresponding product Data sheets.

Chapter 8 FAQs

How to upgrade SigenStor EVDC from 12 kW to 25 kW?

Purchase and activate a license. For specific operation methods, please refer to the chapters "How to Purchase a License?" and "How to Activate a License?" in the *mySigen App User Manual*.